



JIANGSU CHANGJIANG ELECTRONICS TECHNOLOGY CO., LTD

## SOT-23-3L Plastic-Encapsulate MOSFETS

**CJK3415**

$V_{(BR)DSS}$	$R_{DS(on)MAX}$	$I_D$
-20V	50mΩ@-4.5V	-4.0A
	60mΩ@-2.5V	
	73mΩ@-1.8V	

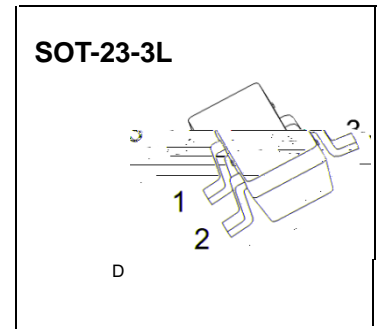

### FEATURE

### APPLICATIONS

MARKING: R15

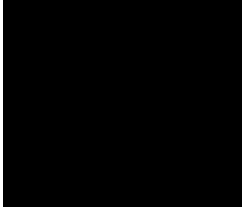

### Equivalent Circuit

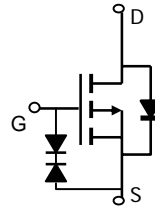

Maximum ratings ( $T_a=25$  unless otherwise noted)

Parameter	Symbol	Value	Unit
$\leq$			
$\leq$		0	
	$\theta$	417	

ules thr s s f 2 nT = 5p e o ew e edie

Parameter	Symbol	Test Condition	Min	Typ	Max	Units
<b>Static Parameters</b>						
				-0.56		
				0.037		Ω
2				0.045		
				0.056		
<b>Dynamic Parameters</b>						
						Ω
<b>Switching Parameters</b>						
		Ω Ω				

Notes:

≤

≤

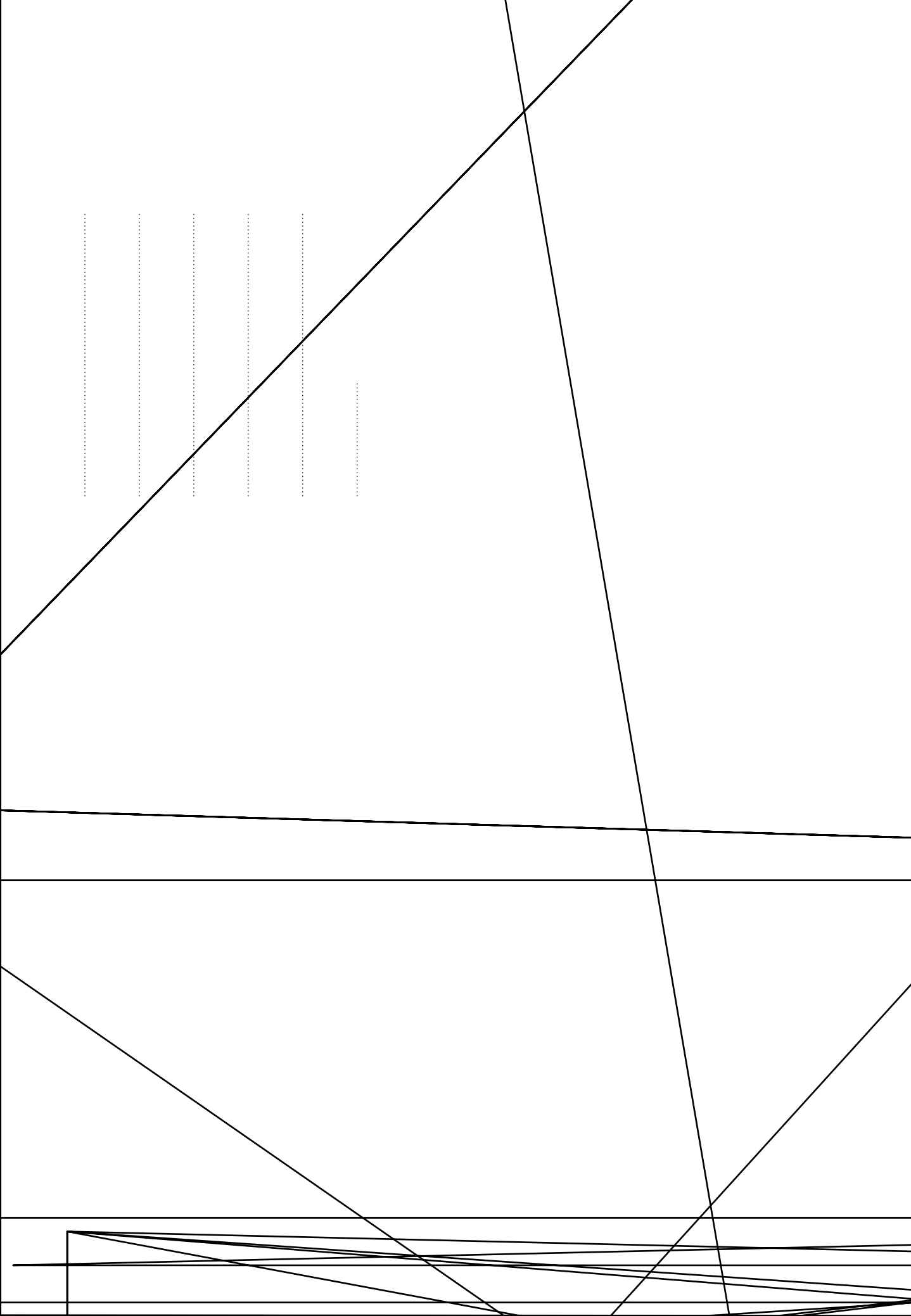

NOTICE

JCET reserve the right to make modifications, enhancements, improvements, corrections or other change

