

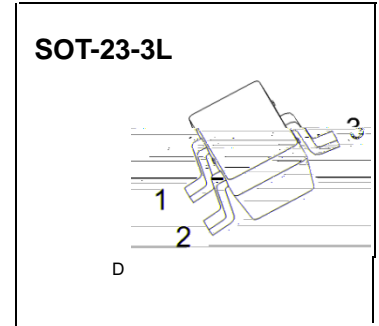

SOT-23-3L Plastic-Encapsulate MOSFETS

CJK2305

$V_{(BR)DSS}$	$R_{DS(on)MAX}$		I_D
12	45	4.5	1
	60	2.5	
	90		



FEATURE

APPLICATIONS

-
-

MARKING:

Equivalent Circuit

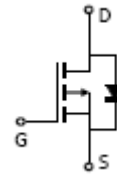
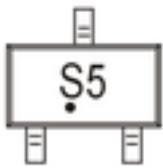

Solid dot = Green molding compound device,
if none, the normal device.

Maximum ratings ($T_a=25^{\circ}C$ unless otherwise noted)

Parameter	Symbol	Value	Unit
	V_{DS}	12	
		4	W
\leq	θ	12.5	$^{\circ}C$
			$^{\circ}C$

Parameter	Symbol	Test Condition	Min	Typ	Max	Units
Static						
			12			
			5		0.9	
				30	5	mΩ
				40	6	
				60	90	
Dynamic						
						Ω
		Ω ≈ Ω				
		Ω ≈ Ω				
Drain-source body diode characteristics						
		°C				

Note :

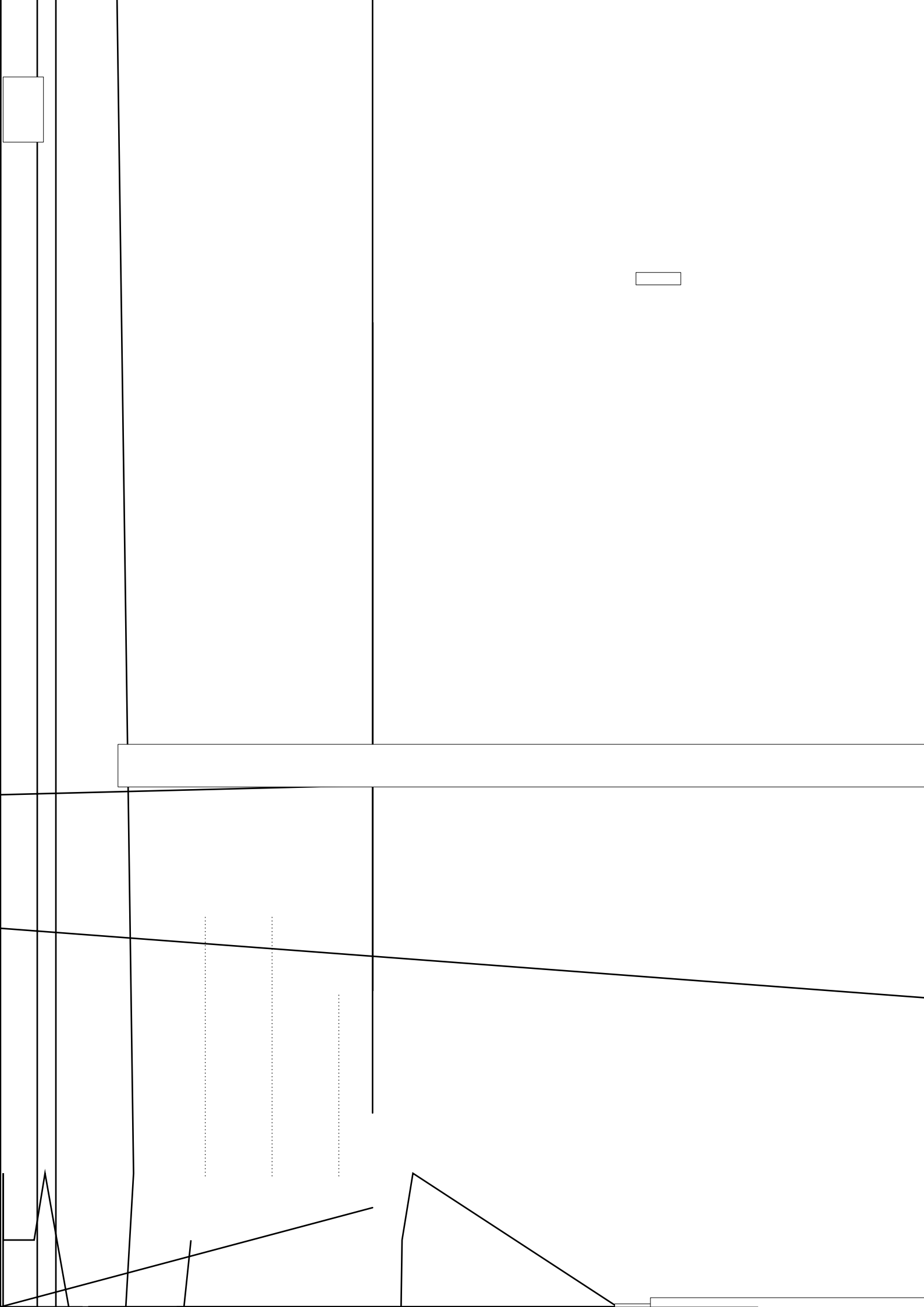

NOTICE

JCET reserve the right to make modifications,enhancements, improvements, corrections or other change

